



# VERTEX F series

## Instruction Manual

The VERTEX F4 controller 1/16 DIN is our NEW LOW COST yet HIGH SPEC controller. Configurable on input between various thermocouples from the keypad by the user or with basic instrumentation skills between thermocouples, PT100, "linear mA", "linear mV" and Voltage. Choose between "Relay Output" or "Solid State Relay Output" or to have a second alarm when ordering. It comes standard with the main heating output and one relay alarm but you can order it with the main output converted to a full function second alarm. There are two optional extras, firstly the RS485 comm's used for networking and or MMI interfacing and the IP65 gasket option. Without the gasket the basic unit is IP63. (We will have the 1/4 DIN, 72 x 72 DIN, and 1/8 DIN vert. available soon).

### CONTENTS

1.	In A Hurry .....	2
2.	Installing your F4 Controller .....	3
3.	Check Basics of your Controller .....	3
4.	Wiring your F4 Controller .....	3
4.1.	Mains Power .....	4
4.2.	Inputs .....	4
	• Thermocouple .....	4
	• PT100 Inputs .....	4
	• mA (milli amp) Inputs.....	4
	• Voltage Inputs .....	4
	• mV (milli volt) Inputs.....	4
4.3.	Output.....	4
	• Relay Output .....	4
	• Solid State Relay Output .....	5
	• Main output converted to 2nd alarm .....	5
4.4.	Alarm 1.....	5
4.5.	Aux 24 Vdc Power Supply .....	5

4.6. RS485 Communications.....	5
5. Commissioning your F4 Controller .....	5
5.1. Front Panel Description.....	5
5.2. Key Functions .....	5
5.3. Power up Sequence.....	6
5.4. Initial Quick Check.....	6
❖ Activate Output.....	6
❖ Input.....	6
❖ Output.....	7
5.5. Auto Tune your Controller.....	7
6. Parameter Settings.....	9
6.1. Overview .....	9
6.2. User Level.....	10
6.3. Alarm Parameter Level.....	10
6.4. Soft Level.....	13
6.5. PID Level.....	14
6.6. Option Level .....	15
7. Error Messages.....	18

## 1. In A Hurry

**Vertex temperature controllers, although quiet sophisticated, can be very simple to use as well. In its simplest form, all you need to do is install it and get the wiring right, turn it on, check that the thermocouple type is correct, (during the self test it will display the input type), make sure it is reading more or less the right temperature, that the heating elements actually get hot when the “C1” light is on and away you go. No need for laboriously reading this manual and changing and setting all the parameters...Just turn it on and when the system it is controlling has reached its operating temperature, do an “auto-tune” as explained in the section “Tuning your VERTEX F4 controller.” You can also however explore all the parameters and set and use it in any way you may wish. If you are not sure please contact Vertex and ask, we are always happy to help. To change the set point first use the sideways shift key to highlight a digit then use the up and down buttons to set it to the desired value. Press set button on completion. Refer item 5.2 for more key function information.**

## 2. Installing your F4 Controller

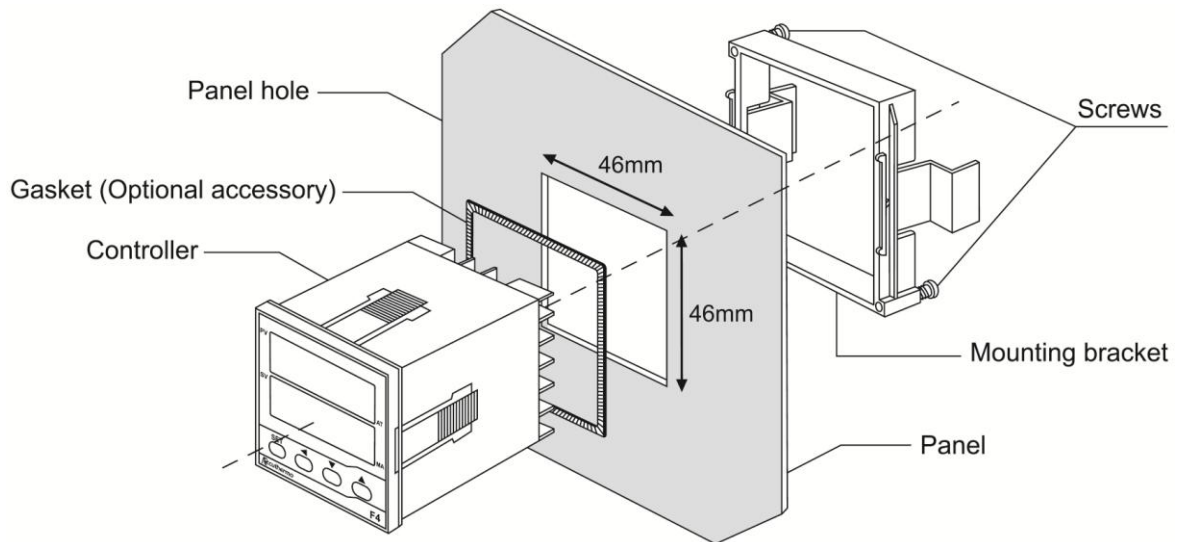

- Fit the controller as shown in the diagram. Cut out size are (45.5 + 0.5mm X 45.5 + 0.5 mm).
- Fitting the controller without the “Gasket” makes it IP63 and with the “Gasket” IP65.

## 3. Check Basics of your Controller

The very first thing to verify exactly what options your controller includes ie: What is the input, what is the output, and does your unit have RS485 comms. This can be done firstly from the Code on the box that will coincide with various options in the selection code below. This will tell you what wiring options to expect. If it is not what you expected you can actually change between any of the inputs yourself, see below, but all the other options must be defined when ordering from the supplier/factory.

Size	Code	Input	Code	Output (Heating)	Code	Optional Extra	Code	Protection	Code
<input type="radio"/> 48 x 48	F4	<input type="radio"/> T/C	T	<input type="radio"/> Relay	R	<input type="radio"/> None	N	<input type="radio"/> IP63	3
<input type="radio"/> 72 x 72	F7	<input type="radio"/> RTD	D	<input type="radio"/> SSR	P	<input type="radio"/> RS485	C	<input type="radio"/> IP65	5
<input type="radio"/> 48w x96h	F8	<input type="radio"/> 4 ~ 20 mA	M	<input type="radio"/> 2nd Alarm	A				
<input type="radio"/> 96x96	F9	<input type="radio"/> 0 ~ 20 mA	L						
		<input type="radio"/> 0 ~ 10 Vdc	O						
		<input type="radio"/> 1 ~ 5 Vdc	V						

## 4. Wiring your F4 Controller

There are generally three sets of wires to connect. The mains power, thermocouple input and relay or “solid state relay” output wires.

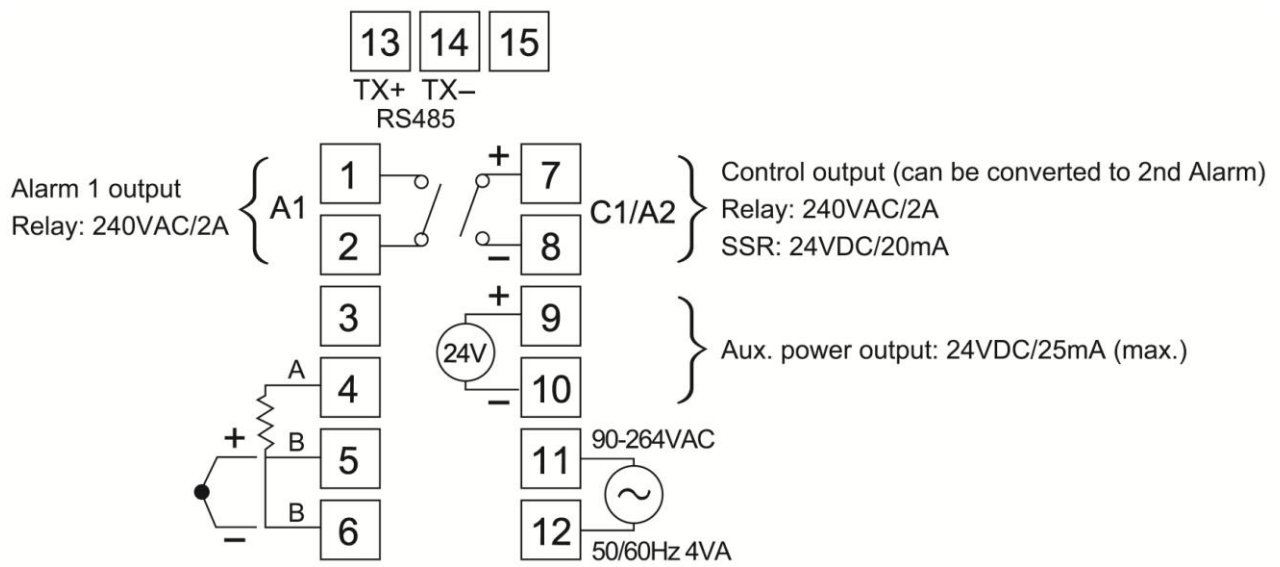

#### 4.1. Mains Power

- Mains power can be anything between 90 and 264 Volts either AC or DC and gets connected to terminals 11 and 12.
- This controller does not cater for a low voltage DC or AC mains power such as 24 V.

#### 4.2. Inputs

- Thermocouple

This controller can accept any of the “thermocouple” inputs shown in the table. The wires for the various thermocouples go on terminal 5 and 6 with T5 being +ve and T6 being -ve. You should check in the parameter settings that the controller is set up to accept the type of thermocouple you are using. Factory default is set to accept type K.

- PT100 Inputs

PT100's generally having 3 wires. The two similar colored wires will go on terminals T5 and T6 and the other one on T4. If your PT100 only has 2 wires simply connect it to T4 and T5 and then install a small bridge wire between T5 and T6.

- mA (milli amp) Inputs

These are either 0~20 mA or 4~20 mA and get connected to T5 (+ve) and T6 (-ve).

- Voltage Inputs

These are typically 0~10 Vdc or 1~5 Vdc etc and are connected to T5 (+ve) and T6 (-ve).

- mV (milli volt) Inputs

These are also connected to T5 (+ve) and T6 (-ve).

#### 4.3. Output

- Relay Output

The relay output is 2A/240Vac (resistive load) potential free relay output but even so never switch a load directly through this relay. For this you use T7 and T8. Always use an interposing relay or contactor to switch the load.

- Solid State Relay Output

The SSR output provides a 24 Vdc on terminals T7 (+ve) and T8 (-ve) which is designed to switch most makes of SSR's that work with a switching voltage of between 3 Vdc and 32 Vdc.

- Main output converted to 2nd alarm

The main output can be converted to become a 2nd Relay alarm output. If this is done then T7 and T8 simply become Alarm 2. This then performs as a second alarm which incorporates all the alarm features. Alarm 2 relay will be a 2A/240Vac (resistive load) potential free relay output.

#### 4.4. Alarm 1

Alarm 1 is connected to T1 and T2 and is a 2A/240Vac (resistive load) potential free relay output.

#### 4.5. Aux 24 Vdc Power Supply

On terminals T9 (+ve) and T10 (-ve) you will find a 24Vdc 25 mA max aux power supply. This is intended to only be used on powering 4 wire analog devices that require an external 24 Vdc like 4~20 mA devices. Do not use this as a power source for any other loads as it will cause functional failures and perhaps permanent damage to your controller.

#### 4.6. RS485 Communications

If you have chosen to have RS485 comms use terminals T13 and T14 for this. Please read our separate user manual on RS485 Comms and Protocol for further information.

## 5. Commissioning your F4 Controller

### 5.1. Front Panel Description

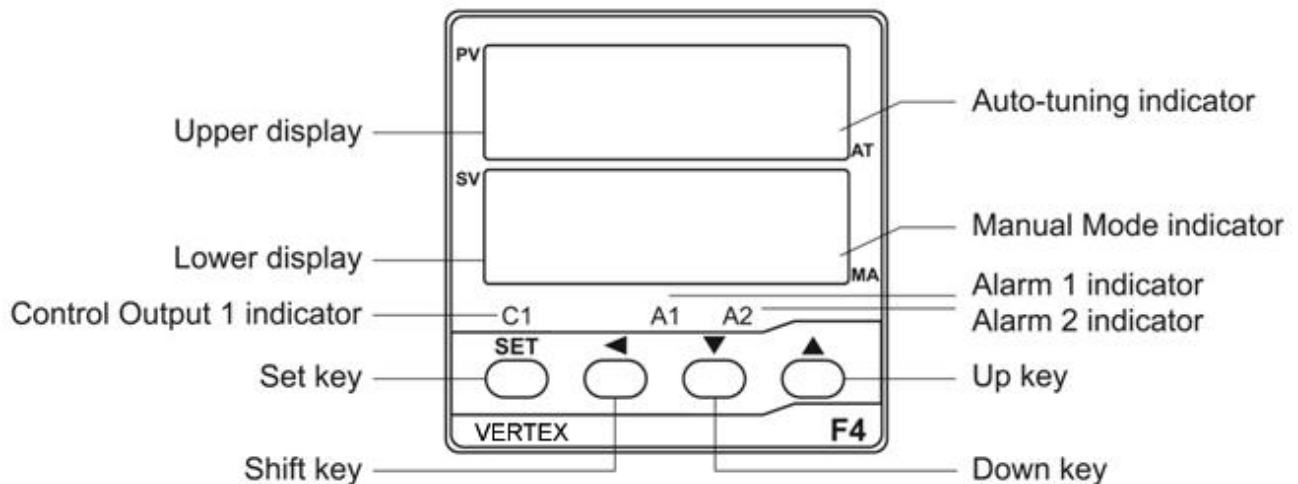

- **PV Display** : Displays the process Value or parameter index code or error code
- **SV (Lower display)** : Display the set point value or the set value of parameter
- **C1** : Control output 1 indicator, shows status of output (on or off)
- **A1** : Alarm 1 status indicator
- **A2** : Alarm 2 status indicator
- **AT** : Auto-tuning indicator (The right-most lower decimal point of display)
- **MA** : Manual mode indicator (The right-most decimal point of lower display)

### 5.2. Key Functions

- **SET key** : Menu navigation and set value changes
- **Shift key** : Shift to select the digit to be changed

- **Down key** : Decrease a parameter value or change a setting
- **Up key** : Increases a parameter value or change a setting
- **SET + Shift key** : Press together for 2 sec's to enter parameters.
- **SET + up key** : Return to PV/SV display (normal position)
- **Shift + Down key** : Pressing together on powering up resets all parameters to factory default setting. No need to re-calibrate but check all user settable parameter.

### 5.3. Power up Sequence

After checking your inputs and wiring it in the panel, on “power up” the controller will perform a series of tests indicating the following.

- The controller will first turn on all segments of the display along with various “led’s” etc to show that they are working.
- It will then momentarily flash showing the “Input Type” and Scale being used as in “Deg C or F”
- It will then flash showing the Upper limit of your measuring range in the PV display and the low limit in the SV display.
- It will then settle at the operating display showing both the measured temperature in the PV display and the set value in the SV display.

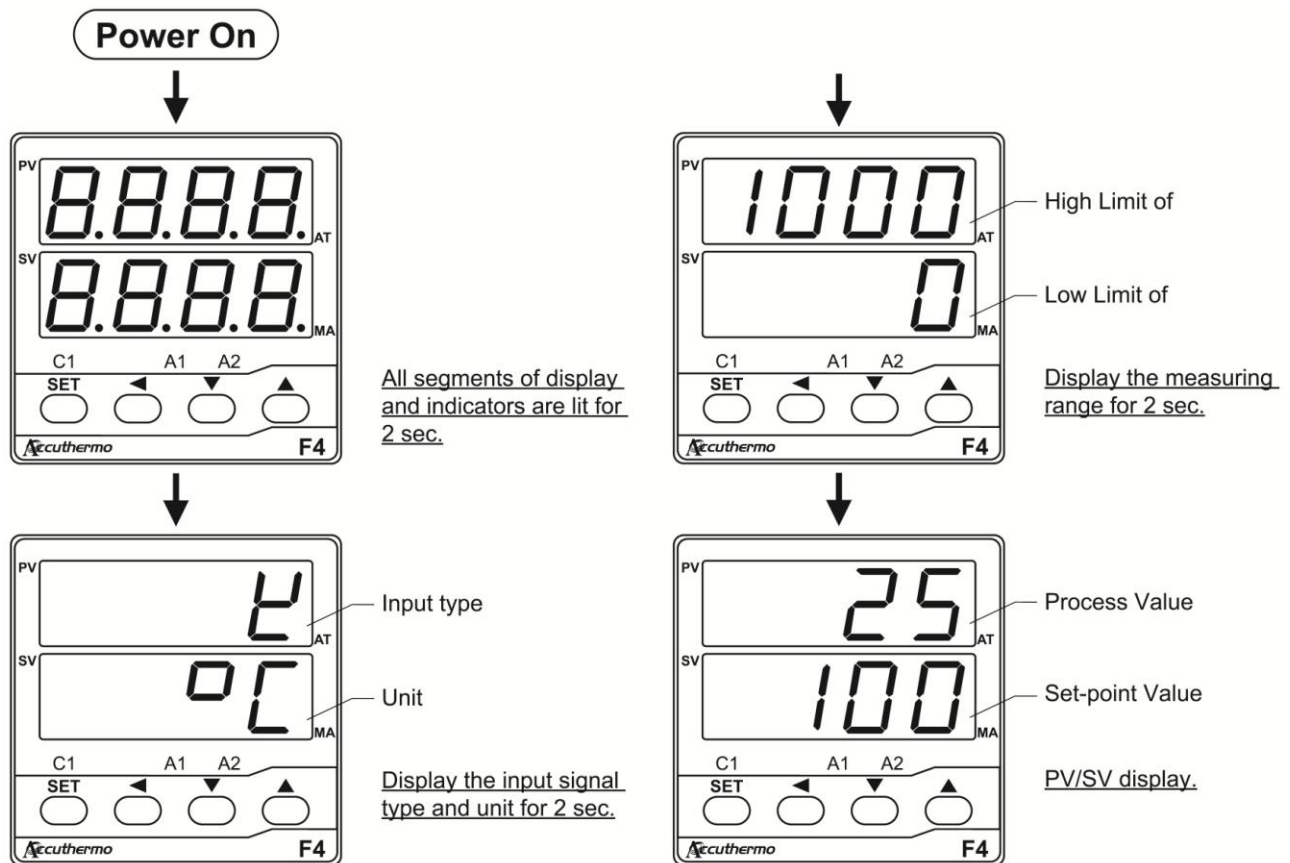

### 5.4. Initial Quick Check

#### ❖ Activate Output

- In the “User level” check that the “run” parameter is set to “on” or the output will be deactivated.

#### ❖ Input

- If the PV display reads “open” it means that there is a problem with the input.

- First check the input typesetting (thermocouple type) and make sure that is the type of thermocouple you are using.
- Then check the wiring etc to do with the input. (Polarity is very important).

#### ❖ Output

- Now make sure that the SV set value is higher than the PV reading. The “C1” led should be lit or flashing on and off indicating that the controller is calling for heat.
- If you are using a “relay” output, when the “C1” led is lit the external interposing contactor or relay or control device should be energized switching the power to the load.
- If you are using a SSR the control led on the SSR should be lit and the heating elements should be getting hot.
- When the “C1” led goes off the external interposing contactor or relay or control device should be off.
- Lastly when the “C1” led is on, the external interposing device is also on, the heating elements should be on and the PV should start rising.

### 5.5. Auto Tune your Controller

- In order to get the best results from your controller it needs to be “tuned” or set for your application dynamics. This is best done automatically by the controller; the process is called “auto tuning”.
- Always set the setpoint at about half the eventual control temperature the first time you turn it on after installing it during commissioning. This will allow the controller to start controlling and you will easily see if there is something wrong.
- If the controller is being used as a PID controller, the output will be on and stay on at first, and the temperature will rise towards the setpoint. As it nears the setpoint it will begin to switch on and off. You can monitor this by watching the “C1” light on the display. When the output is on and it is heating, the light will be on.
- Once the controller has stabilized at that setpoint and is working more or less ok, take the setpoint up to the required temperature and let it re-stabilized there.
- If you are then not happy with the control results you can make the controller set (tune) the PID parameters itself. Should you wish to do this, instruct the controller to do an “auto-tuning” calibration of the parameters.
- Make sure that the value of Pb is not zero ( $Pb = 0$  forces on/off control). Set the **rUn** parameter (to be found in the “user” level to **AL1**. (Note **AL2** will force the tuning process to be done at a point 10% below the setpoint in case your process should not go much above the setpoint.) The rightmost decimal (**AT**) on the PV display will blink during tuning process.

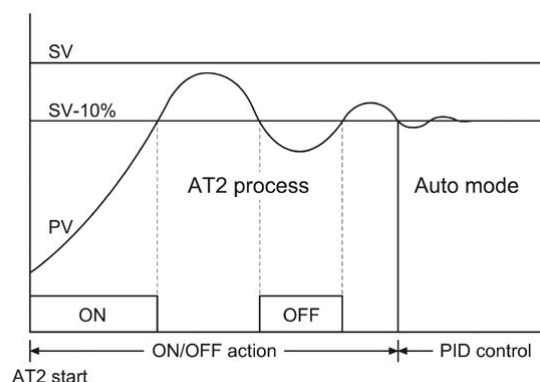
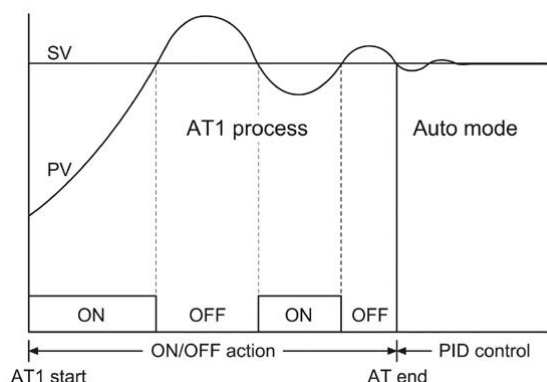

- After two oscillatory cycles of on/off control action around the setpoint (SV) the controller will use the measurements taken to set the PID parameters. The controller will now start controlling using these parameters and should give good control on your system.
- To abort an auto tune process. Simply set the `rUn` to `on` or `oFF`.
- If initially the controller is oscillating badly you may need to perform this procedure a second time to get the best results.
- DO NOT CHANGE ANYTHING AT ALL IN THE PROCESS OR CONTROLLER WHILE DOING AN AUTO TUNING PROCESS.
- Do not change anything during this procedure, as it will result in erroneous settings that may not control well at all. (Just leave the system for a few minutes while it does its thing).
- Also only do this at the full-required temperature, once the whole system has had a chance to warm up and work for a while.
- Once it has finished the auto tune light will stop flashing and the controller will start to control using the new parameters.
- Once this is done during initial setup and commissioning it should not be necessary to do it again unless you change something substantial or the performance changes unsatisfactorily.

Your controller should work perfectly now.

## 6. Parameter Settings

Please note that in most applications, when you ordered your controller it will be configured so that all you need to do is install it and follow the steps outlined in section 5 above. However to use and access features like the alarm you will need to enter the parameter sections.

### 6.1. Overview

The parameters are to be found in 5 levels ie: User, Alarm, Soft, PID and Option.

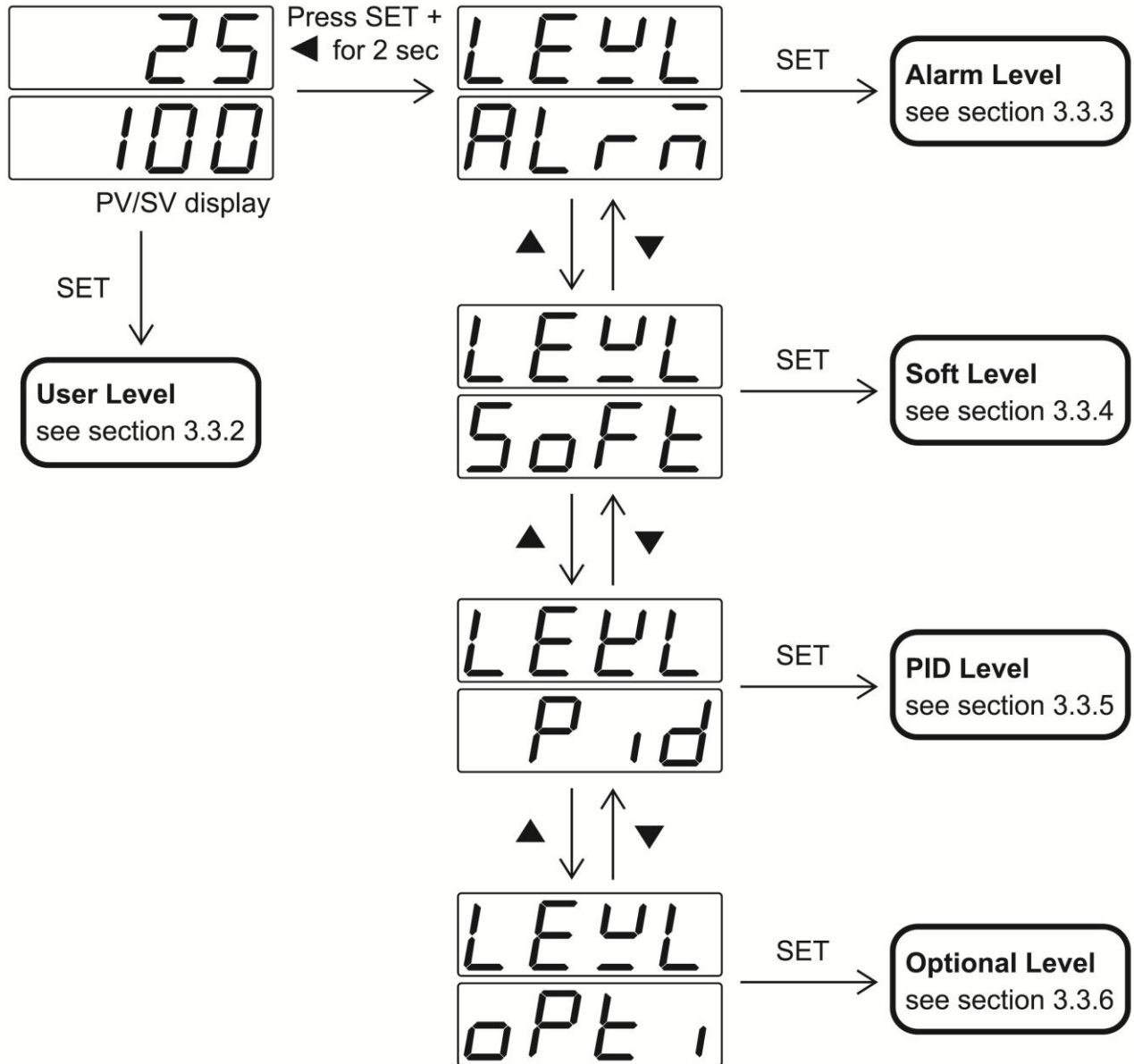

These can be accessed in the following way...

- User Level Simply press the "SET" key to scroll through the "User" level.
- Alarm Level Press the "SET + Sideways Shift" keys together for 2 seconds.
- Soft Level Once the PV display reads "Level" simply use the up and down keys to scroll through the balance of parameter levels as shown above.
- PID Level Once the PV display reads "Level" simply use the up and down keys to scroll through the balance of parameter levels as shown above.
- Option Level Once the PV display reads "Level" simply use the up and down keys to scroll through the balance of parameter levels as shown above.

## 6.2. User Level

Display	Description	Range	Default	Unit
<i>PV<sub>OFF</sub></i>	Process value offset correction	-1000~1000 ( <i>dP</i> =0000) -100.0~100.0( <i>dP</i> =000.0) -10.00~10.00( <i>dP</i> =00.00) -1.000~1.000( <i>dP</i> =0.000)	0	
<i>OUTL</i>	Control output percentage	0.0~100.0%	N/A	%
<i>rUn</i>	Control mode selection	<i>oFF</i> : Off <i>on</i> : On <i>At1</i> : AT1 <i>At2</i> : AT2 <i>nAn</i> : Man	On	-

### ❖ Process Value Offset Correction

- This parameter allows for manual manipulation of any process off-set that may exist between the measurement of the probe and the reading on the controller PV display.

### ❖ Control Output Percentage

- In Auto mode ( *rUn* = *on* ), it reflects the output, as a percentage, of power applied to the load.
- In Manual mode ( *rUn* = *nAn* ), the upper display will alternatively display the process value setting (PV) and “OUTL” percentage respectively (while the “MA” indicator is lit). The output value of percentage can be changed manually using the up and down keys.

### ❖ Control Mode Selection

The following options are available:

- Off –Standby mode. Both the control output and alarm are turned off. (disabled).
- On –Auto mode. In this mode the control output is determined by the controller.
- AT1 –Auto-tuning mode 1. In this mode, the controller will tune the PID parameters automatically at the SV level. (Read item 5.5 above).
- AT2 –Auto-tuning mode 2. In this mode, the controller will tune the PID parameters automatically at (SV-10%). (Read item 5.5 above).
- Man –Manual mode. In this mode, the value of the control output can be set manually.

## 6.3. Alarm Parameter Level

This controller has one alarm but you can order it with the “main control output” converted to become a second alarm should you so require. So it can be a PID controller with one alarm or simply an indicator with two alarms depending on your needs. The relay output for the alarm is rated at 240 Vac 2 amps.

In the parameter settings under “Alarm Level” you will find the following parameters.

Display	Description	Range	Default	Unit
<i>A1SP</i>	Alarm 1 set-point	-1999 ~ 9999 ( <i>dP</i> =0000) -199.9 ~ 999.9 ( <i>dP</i> =000.0) -19.99 ~ 99.99 ( <i>dP</i> =00.00) -1.999 ~ 9.999 ( <i>dP</i> =0.000)	10	unit
<i>A1HY</i>	Alarm 1 hysteresis	0~ 9999 ( <i>dP</i> =0000) 0~999.9 ( <i>dP</i> =000.0) 0~99.99 ( <i>dP</i> =00.00) 0~9.999 ( <i>dP</i> =0.000)	0	unit
<i>A1FU</i>	Alarm 1 function	<i>AoFF</i> : A.oFF <i>AHi</i> : A.Hi <i>ALo</i> : A.Lo <i>AdiH</i> : A.diH <i>AdiL</i> : A.diL <i>AbdH</i> : A.bdH <i>AbdL</i> : A.bdL <i>boFF</i> : b.oFF <i>bHi</i> : b.Hi <i>bLo</i> : b.Lo <i>bd iH</i> : b.diH <i>bd iL</i> : b.diL <i>bbdH</i> : b.bdH <i>bbdL</i> : b.bdL	A.diH	N/A
<i>A1m̄d</i>	Alarm 1 mode	<i>none</i> : None <i>Stdy</i> : Stdy <i>LAtH</i> : LAtH <i>StLA</i> : StLA	None	N/A
<i>A1dt</i>	Alarm 1 delay time	oFF, 00.01~99.59	oFF	HH.MM/MM.SS
<i>A2SP</i>	Alarm 2 set-point*	Same as Alarm1 set-point	10	Unit
<i>A2HY</i>	Alarm 2 hysteresis*	Same as Alarm1 hysteresis	0	Unit
<i>A2FU</i>	Alarm 2 function*	Same as Alarm1 function	A.diL	N/A
<i>A2m̄d</i>	Alarm 2 mode*	Same as Alarm1 mode	None	N/A
<i>A2dt</i>	Alarm 2 delay time*	Same as Alarm1 delay time	oFF	HH.MM/MM.SS

<i>A1SP / A2SP</i>	This is the alarm setpoint.
<i>A1HY / A2HY</i>	This is where the “hysteresis” for each alarm is set. You can see from the detail below how it works but in principle prevents the alarm from unwanted “on off” switching around the alarm setpoint. This feature lends itself to some clever applications and uses.
<i>A1FU / A2FU</i>	This is where you set how the “alarm” works amongst other things being able to reverse the state of the “normal” relay status. It does not however actually change it from normally open to normally closed, but makes it work as if it were. <b>With no power it will always be a normally open contact.</b> Please see the table below for detail.
<i>A1m̄d</i>	You can set how the alarm functions in relation to the process variable by choosing one of the parameters in the A1Fu section then over and above that you can set use these parameter settings to dictate when and how the alarm functions. See the more detailed description below.
<i>A1dt</i>	This allows the user to set a “delay” time after the alarm condition has been met before the relay changes state.

Function	Description	Operation
Note:	In the strictest sense we only use "Form A" relay (s) (normally open) for all these options but in the second half of this table the relay is electrically made to behave like a "Form B" relay. (Normally closed). With no power on the controller the alarm relay (s) will always be open.	
Note:	☀ Alarm indicator on	● Alarm indicator off
<i>R<sub>oFF</sub></i>	Alarm deactivated	
<i>r<sub>H</sub></i>	Process high alarm with Form A contact (Form A means normally open and makes when condition met)	
<i>r<sub>Lo</sub></i>	Process low alarm with Form A contact	
<i>r<sub>d</sub> i<sub>H</sub></i>	Deviation high alarm with Form A contact	
<i>r<sub>d</sub> i<sub>L</sub></i>	Deviation low alarm with Form A contact	
<i>r<sub>b</sub> d<sub>H</sub></i>	Deviation band high alarm with Form A contact	
<i>r<sub>b</sub> d<sub>L</sub></i>	Deviation band low alarm with Form A contact	
Function	Description	Operation
<i>b<sub>oFF</sub></i>	Alarm deactivated	
<i>b<sub>H</sub></i>	Process high alarm that behaves like a Form B contact (Form B means normally closed and opens when condition met)	
<i>b<sub>Lo</sub></i>	Process low alarm that behaves like a Form B contact	
<i>b<sub>d</sub> i<sub>H</sub></i>	Deviation high alarm that behaves like a Form B contact	
<i>b<sub>d</sub> i<sub>L</sub></i>	Deviation low alarm that behaves like a Form B contact	
<i>b<sub>b</sub> d<sub>H</sub></i>	Deviation band high alarm that behaves like a Form B contact	
<i>b<sub>b</sub> d<sub>L</sub></i>	Deviation band low alarm that behaves like a Form B contact	

- Alarm Mode Setting

As mentioned before after selecting how the alarm works in the A1Fu section you can set other related options here that effect how and when it works. You can select one of the following modes:

- **None** Disables alarm mode options.
- **Stdy** Standby mode. When selected it prevents an alarm on power up until the alarm setpoint has been reached and cleared and only then will it activate.
- **LAtH** Latch mode. This causes the alarm output and indicator to latch as the alarm condition is met and remain so until the controller power has been switched off and back on again.
- **StLA** Both standby and Latch modes are applied.

#### 6.4. Soft Level

This level has two parameters that function as follows:

Display	Description	Range	Default	Unit
<i>rAñP</i>	Ramp rate	oFF, 1 ~9999 (0.1~999.9)	oFF	
<i>Soft</i>	Soft start time	oFF,00.01~99.59	oFF	

- Ramp Rate Setting

The controller can have a single ramp function if activated. To deactivate simply set this parameter to “off”. The ramp function works in two ways, on power up it will ramp at the pre-set rate up or down to the setpoint, or each time you change the SV set value it will make the change from where it was to the new set value at the pre-set ramp rate. The ramp rate is set in degree per min. or sec. depends on the time scale set in PTME.

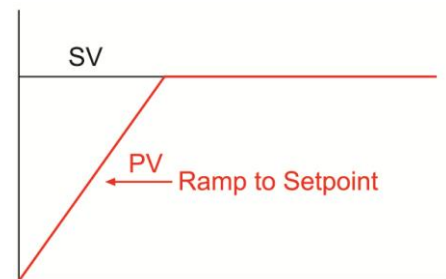

- Soft Start

The “Soft Start” function allows you to limit the power applied to a load from initial startup ramping from 0% to 100% over the time you have set.

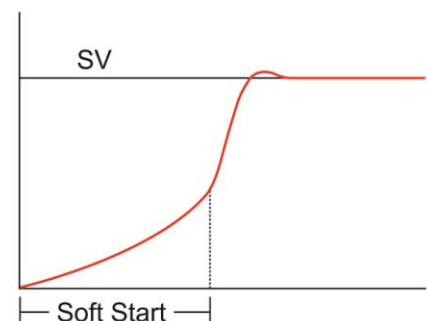

## 6.5. PID Level

Display	Description	Range	Default	Unit
<i>Pb</i>	Proportional band	0.0~300.0	5.0	%
<i>ti</i>	Integral time	oFF, 1~3000	240	Sec.
<i>td</i>	Derivative time	oFF, 1~1000	60	Sec.
<i>rr</i>	Manual reset	0.0~51.0	0.0	%
<i>Ar</i>	Anti-reset windup	0.0~100.0	50.0	%
<i>HYS</i>	Hysteresis for ON/Off control	0~1000 (0.0~100.0)	0	unit
<i>CT</i>	Cycle time	1~60	15	Sec.

- Proportional Band Setting  
This can be set automatically by using the “auto tune” function or set manually here as a percentage of the controller SPAN (High limit – Low limit). This part of the algorithm causes an output change based on any offset created between the PV and SV.
- Integral time  
This can be set automatically by using the “auto tune” function or set manually here as a time constant in repetitions per seconds. This part of the algorithm causes an output change based on the initial change derived by Pb and repeated in the “integral” time set to re-establish control at the SV.
- Derivative time  
This can be set automatically by using the “auto tune” function or set manually here as a time constant in seconds. This portion of the algorithm causes an output change based on the “rate” of initial change.  
To read a bit more about PID please visit our web site at <http://www.qis-k.co.uk/Manuals/contrwt.pdf>.
- Manual Reset  
For PID control, this value is set automatically by the auto-tuning process. For P only control, it is used to compensate for any deviation that may exist between the process value and set point. In old terms called “manual reset”.
- Anti-reset windup  
The anti-reset windup shuts off the reset action (integral term) any time the measurement is outside of this band to prevent the reset action from saturating. Reset action begins again when the measurement (PV) returns to within the band.
- Hysteresis for on/off control

In ON/OFF control (Proportional band set to 0.0%), the control output turns On/Off around the set point. To avoid unwanted on/off changes in response to small oscillations around the setpoint we have provided the “hysteresis” setting that introduces a band that works as shown in the drawing.

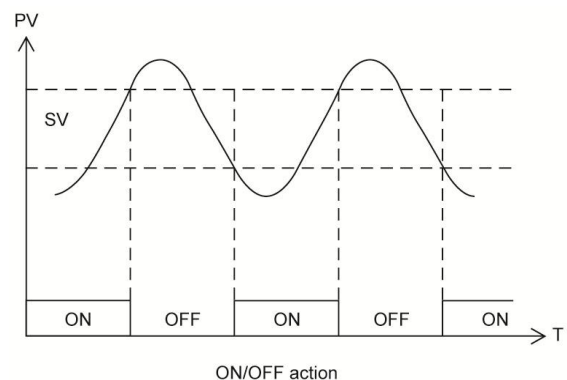

- Cycle Time

In an on/off controller where power to the load is regulated by switching the output on and off against time it is best done in measurable blocks of time called the “cycle time”. This is

generally set to 15 seconds per block for a relay output controller or 1 second for a SSR output. In its simplest form with a relay output controller 50% of power would be applied by having the output on for half of 15 seconds and off for the other half.

## 6.6. Option Level

Display	Description	Range	Default	Unit
<i>TYPE</i>	Input signal type	<i>J</i> : J type <i>K</i> : K type <i>T</i> : T type <i>E</i> : E type <i>b</i> : B type <i>r</i> : R type <i>S</i> : S type <i>n</i> : N type <i>C</i> : C type <i>d-PE</i> : PT100(DIN) <span style="border: 1px solid red; padding: 2px;"><i>JPE</i></span> : PT100(JIS) <i>nA</i> : mA <i>nV</i> : mV <i>V</i> : V	K type	N/A
<i>SCAL</i>	Low scale for linear input	-1999~9999	0	Unit
<i>SCAH</i>	High scale for linear input	-1999~9999	1000	Unit
<i>CUT</i>	Cut-off function	<i>none</i> : None <i>Lo</i> : Low <i>Hi</i> : High <i>HiLo</i> : High/Low	None	N/A
<i>Unit</i>	Unit	<i>°C</i> : °C <i>°F</i> : °F <i>Eng</i> : Engineer	°C	N/A
<i>DP</i>	Decimal point	0000 000.0 00.00 (for linear input signal only) 0.000 (for linear input signal only)	0000	N/A
<span style="border: 1px solid red; padding: 2px;"><i>ACT</i></span>	Control action	<span style="border: 1px solid yellow; padding: 2px;"><i>dir</i></span> : Dir <span style="border: 1px solid yellow; padding: 2px;"><i>rev</i></span> : Rev	Rev	N/A
<i>LoLt</i>	Low limit	Refer to table 1.	0	Unit
<i>HiLt</i>	High limit	Refer to table 1.	1000	Unit
<i>FiLt</i>	Digit filter	0.0~99.9	0.0	Sec.
<i>PEnE</i>	Time scale	<span style="border: 1px solid red; padding: 2px;"><i>HHmm</i></span> : HH.MM <span style="border: 1px solid red; padding: 2px;"><i>mmSS</i></span> : MM.SS	HH.MM	N/A
<i>ErOP</i>	Error protection	0000 0001 0010 0011	0000	N/A

<i>LoCk</i>	Security lock	0000 0001 0010 0011 0100 0101 0110	0110	N/A
<i>SetoF</i>	Setpoint offset	-1999~9999 ( <i>dP</i> =0000) -199.9~999.9 ( <i>dP</i> =000.0) -19.99~99.99 ( <i>dP</i> =00.00) -1.999~9.999 ( <i>dP</i> =0.000)	0	Unit
<i>id</i>	Communication ID	1~255	247	N/A
<i>BAUD</i>	Baud rate	<i>2.4K</i> : 2.4K <i>4.8K</i> : 4.8K <i>9.6K</i> : 9.6K <i>19.2K</i> : 19.2K	19.2K	bps

- Input Signal Type

If you ordered a T/C input controller, you can change between any one of the thermocouples shown in the table above, without a need for recalibration, from the keypad by accessing this option level. With basic instrumentation skills you can change between thermocouples, PT100, linear mA, linear mV and Voltage. In order to do this you need to change links as shown below, again without a need for recalibration but you should define the “Low Scale”, “High Scale” and if required the “Cut-off” limits.

	<b>G1</b>	<b>GA1</b>	<b>GB1</b>	<b>GY</b>
<b>Thermocouple</b>	Linked	Linked	Open	Open
<b>RTD</b>	Open	Linked	Open	Open
<b>0~20 mA</b>	X	Linked	Open	Linked
<b>-60~60 mV</b>	X	Linked	Open	Open
<b>-10 ~10 V</b>	X	Open	Linked	Open
X = Don't care				

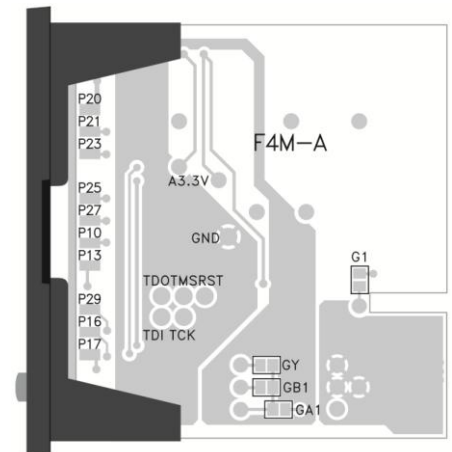

Thermocouples: Available as shown above in the table.

RTD : PT100 (JIS standard) or PT100 (DIN standard) Here in Europe we use DIN standard.

Linear : 0~24mA, -60~60 mV or 0~10 V After changing the links you specify the high and low scale limits (ie: 4~20 mA etc).

- Define “Low” and “High” Scale parameter for analog inputs

Low Scale: The default value for mA is 4.00 mA, for mV is 0.00 mV and for volts is will be

0.00V. You can change this simply by accessing this parameter and changing it. This parameter is only displayed when the input signal type is set to linear.

**High Scale:** The default value for mA is 20.00 mA, for mV is 50.00 mV and for volts is 10.00V. You can change this simply by accessing this parameter and changing it. This parameter is only displayed when the input signal type is set to linear.

- Cut-Off Function

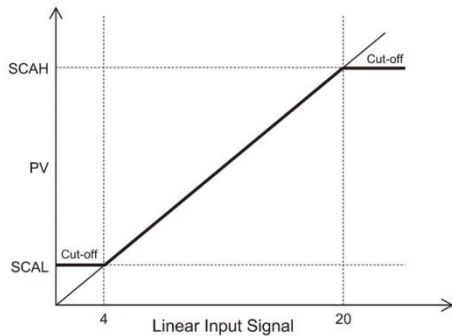

The Cut-off function is used to limit the input signal **display (PV)** within the limits defined by the user whenever the input signal is out of the scale defined by **SCAL** and **SCAH**. The cut-off function can be set to “Low”, “High” or “High/Low” or set to “None” to disable it. The cut-off function has no effect for input signals other than linear types and is only showed when the input signal type is set to linear.

- Unit : Select the process value indication to be either °C or °F when the input signal type is thermocouple or PT100. Select **ENG** unit for linear inputs like mA, mV or V.
- Decimal Point : Select the decimal point position. The setting 00.00 and 0.000 is available for linear inputs only.
- Control Action : Dir – Direct action used for cooling processes.  
Rev – Reverse action used for heating processes.
- Low Limit : Set the low limit of the **measuring range**. When the input goes below the low limit, the PV display will start flashing to indicate that you are out of range and the control output and alarm will be forced according to the “error protection” selected.
- High Limit : Set the high limit of the measuring range. When the input goes above this limit the PV display will start flashing to indicate that you are out of range and the control output and alarm will be forced according to the “error protection” selected.
- Digital Filter This parameter can be used to smooth an unstable input signal if it is uncontrollable. Set the time constant for the digital filter (the first order filter) depending on how unstable the input is. The example below shows the result when no filter is used, when a 1 second and finally 15 second filter is used.

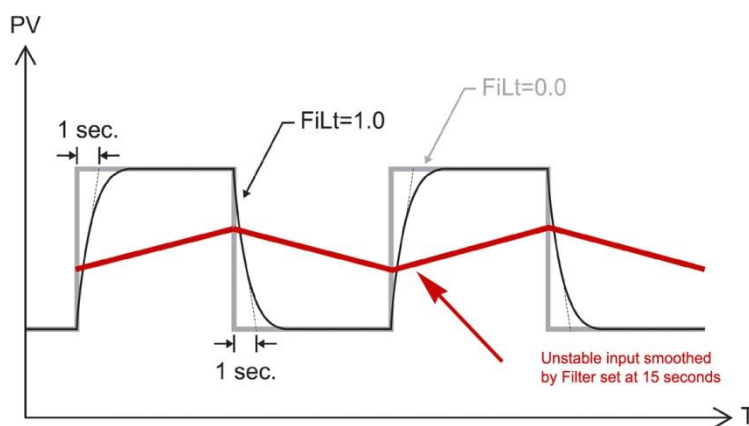

uncontrollable. Set the time constant for the digital filter (the first order filter) depending on how unstable the input is. The example below shows the result when no filter is used, when a 1 second and finally 15 second filter is used.

- Time Scale Set the time scale to be used for alarm delay time and or ramp rate.  
 HH.MM – The alarm delay time is in hour and minute. The ramp rate is in per minute.  
 MM.SS – The alarm delay time is in minute and second. The ramp rate is in per second.
- Error Protection If an error occurs you can dictate the failure mode of the main control output and alarm relay. This of course excludes power failure as both relays will fail open because of their relay form design.

Error Protection	Alarm	Control Output
0000	Off	Off
0001	Off	On
0010	On	Off
0011	On	On

- Security Lock The security lock is designed to prevent unauthorized access to various levels.

0000	Only the security lock parameter can be changed in this level.
0001	Only the security lock and set point parameter can be changed in this level.
0010	The user level can be changed in this level.
0011	The user and alarm levels can be changed in this level.
0100	The user, alarm and soft levels can be changed in this level.
0101	The user, alarm, soft and PID levels can be changed in this level.
0110	All parameters can be changed in this level.

- Setpoint Offset Using this you can introduce an invisible control offset so that when the SV (set value) as an example reads 100, if you have an offset of -10, the actual control point will be at 90.
- Communication ID This sets the device address on a RS485 network.
- Baud Rate Sets the communication baud rate.

## 7. Error Messages

Display	Error Description	Correction
<i>oPEr</i>	No input signal is being received.	Check that wiring connections are correct, check field wiring, and check the probe itself. Check that parameter probe “type” selected matches the probe you are using. Finally if you are using a thermocouple you can short out the two input terminals and the display should read roughly ambient. Change the probe. Call us for help !
<i>AdEr</i>	Input signal is out of A/D convertor range.	1. Check the sensor is connected correctly and input signal type is selected correctly. 2. Replace the sensor. 3. Return to the supplier for investigation.
<i>EPER</i>	The content of	Reset all parameters and settings to the factory default setting by pressing

	EEPROM is corrupt	shift and down keys simultaneously while turning the power on. There is no need to recalibrate the controller after this procedure but all user settable parameters should be re-set. Return to the supplier for repairing.
<i>ALEr</i>	Auto Tune Error	The controller has failed to complete the auto tune process in 2 hours. Retry the auto-tuning process a second time or improve the control process to have faster response and then try again or use manual tuning to set the PID parameters.
Flashing	The PV is out of range	Check the sensor is connected correctly and input signal type is selected correctly. And that the polarity of the sensor is connected correctly. Check the high/low limit parameter is set properly. Replace the sensor.